

HTD[®] PILOT BORE " PHOSPHATED " PULLEYS

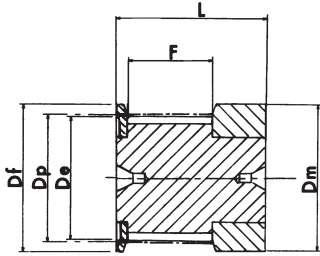

EXECUTION 0F

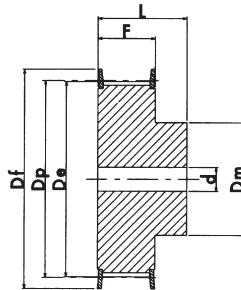

EXECUTION 1F

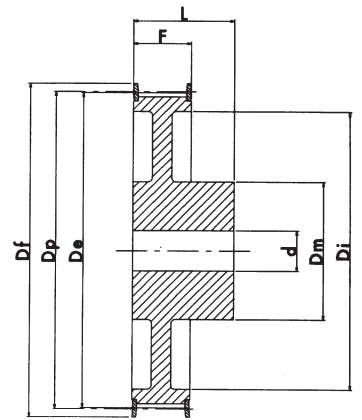

EXECUTION 2F

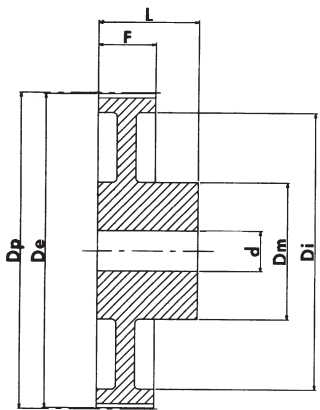

EXECUTION 3

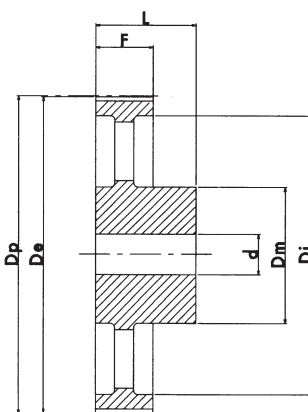

EXECUTION 4

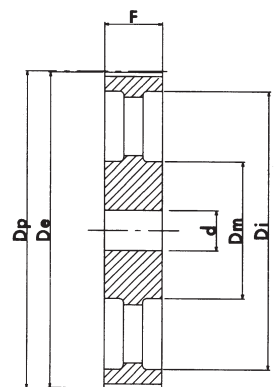

EXECUTION 5

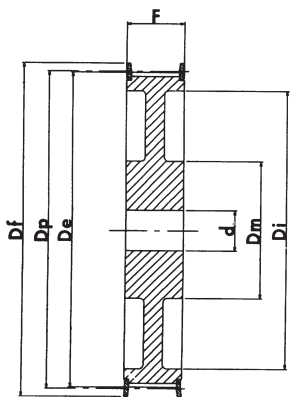

EXECUTION 6F

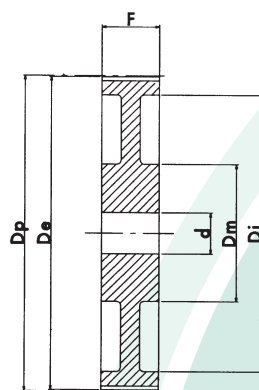

EXECUTION 7

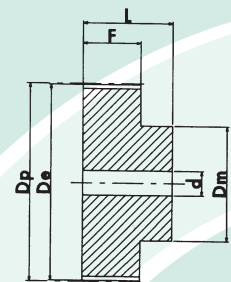

EXECUTION 8

HTD[®] PILOT BORE " PHOSPHATED " PULLEYS

HTD[®] 3M 09

CHARACTERISTICS	TYPE	No. of TEETH	EXEC.	Dp PITCH LINE	De EXTERNAL	Df FLANGE	Dm HUB	F	L	d bore Ø	FLANGE No.		
ALUMINIUM	WITH FLANGE	10-3M-09	10	OF	9.55	8.79	13.0	13.0	10.2	17.5	-	501	
		12-3M-09	12	OF	11.46	10.70	15.0	15.0	10.2	17.5	-	502	
		14-3M-09	14	OF	13.37	12.61	16.0	16.0	10.2	17.5	-	503	
		15-3M-09	15	OF	14.32	13.56	17.5	17.5	10.2	17.5	-	516	
		16-3M-09	16	1F	15.28	14.52	17.5	10.0	12.8	20.6	4.0	504	
		18-3M-09	18	1F	17.19	16.43	20.0	11.0	12.8	20.6	6.0	505	
		20-3M-09	20	1F	19.10	18.34	23.0	13.0	12.8	20.6	6.0	517	
		21-3M-09	21	1F	20.05	19.29	25.0	14.0	12.8	20.6	6.0	518	
		22-3M-09	22	1F	21.01	20.25	25.0	14.0	12.8	20.6	6.0	518	
		24-3M-09	24	1F	22.92	22.16	25.0	14.0	12.8	20.6	6.0	518	
		26-3M-09	26	1F	24.83	24.07	28.0	16.0	12.8	20.6	6.0	508	
		28-3M-09	28	1F	26.74	25.98	32.0	18.0	12.8	20.6	6.0	509	
		30-3M-09	30	1F	28.65	27.89	32.0	20.0	12.8	20.6	6.0	509	
		32-3M-09	32	1F	30.56	29.80	36.0	22.0	12.8	20.6	6.0	510	
		36-3M-09	36	1F	34.38	33.62	39.0	26.0	13.4	22.2	6.0	519	
		40-3M-09	40	1F	38.20	37.44	42.0	28.0	13.4	22.2	6.0	513	
		44-3M-09	44	1F	42.02	41.26	48.0	33.0	13.4	22.2	6.0	520	
		WITHOUT FLANGE	48-3M-09	48	8	45.84	45.08	-	33.0	13.4	22.2	8.0	-
			60-3M-09	60	8	57.30	56.54	-	33.0	13.4	22.2	8.0	-
			72-3M-09	72	8	68.75	67.99	-	33.0	13.4	22.2	8.0	-

HTD[®] 3M 15

CHARACTERISTICS	TYPE	No. of TEETH	EXEC.	Dp PITCH LINE	De EXTERNAL	Df FLANGE	Dm HUB	F	L	d bore Ø	FLANGE No.		
ALUMINIUM	WITH FLANGE	10-3M-15	10	OF	9.55	8.79	13.0	13.0	17.0	26.0	-	501	
		12-3M-15	12	OF	11.46	10.70	15.0	15.0	17.0	26.0	-	502	
		14-3M-15	14	OF	13.37	12.61	16.0	16.0	17.0	26.0	-	503	
		15-3M-15	15	OF	14.32	13.56	17.5	17.5	17.0	26.0	-	516	
		16-3M-15	16	1F	15.28	14.52	17.5	10.0	19.5	26.0	4.0	504	
		18-3M-15	18	1F	17.19	16.43	20.0	11.0	19.5	26.0	6.0	505	
		20-3M-15	20	1F	19.10	18.34	23.0	13.0	19.5	26.0	6.0	517	
		21-3M-15	21	1F	20.05	19.29	25.0	14.0	19.5	26.0	6.0	518	
		22-3M-15	22	1F	21.01	20.25	25.0	14.0	19.5	26.0	6.0	518	
		24-3M-15	24	1F	22.92	22.16	25.0	14.0	19.5	26.0	6.0	518	
		26-3M-15	26	1F	24.83	24.07	28.0	16.0	19.5	26.0	6.0	508	
		28-3M-15	28	1F	26.74	25.98	32.0	18.0	19.5	26.0	6.0	509	
		30-3M-15	30	1F	28.65	27.89	32.0	20.0	19.5	26.0	6.0	509	
		32-3M-15	32	1F	30.56	29.80	36.0	22.0	19.5	26.0	6.0	510	
		36-3M-15	36	1F	34.38	33.62	39.0	26.0	20.0	30.0	6.0	519	
		40-3M-15	40	1F	38.20	37.44	42.0	28.0	20.0	30.0	6.0	513	
		44-3M-15	44	1F	42.02	41.26	48.0	33.0	20.0	30.0	6.0	520	
		WITHOUT FLANGE	48-3M-15	48	8	45.84	45.08	-	33.0	20.0	30.0	8.0	-
			60-3M-15	60	8	57.30	56.54	-	33.0	20.0	30.0	8.0	-
			72-3M-15	72	8	68.75	67.99	-	33.0	20.0	30.0	8.0	-

HTD[®] PILOT BORE " PHOSPHATED " PULLEYS

HTD° 5M 09

CHARACTERISTICS	TYPE	No. of TEETH	EXEC.	Dp PITCH LINE	De EXTERNAL	Df FLANGE	Dm HUB	Di	F	L	d bore Ø	FLANGE No.			
STEEL	WITH FLANGE	12-5M-09	12	1F	19.10	17.96	23.0	13.0	-	14.5	20.0	4.0	14		
		14-5M-09	14	1F	22.28	21.14	25.0	13.0	-	14.5	20.0	6.0	2		
		15-5M-09	15	1F	23.87	22.73	28.0	16.0	-	14.5	20.0	6.0	4		
		16-5M-09	16	1F	25.46	24.32	28.0	16.5	-	14.5	20.0	6.0	4		
		18-5M-09	18	1F	28.65	27.51	32.0	20.0	-	14.5	20.0	6.0	6		
		20-5M-09	20	1F	31.83	30.69	36.0	23.0	-	14.5	22.5	6.0	8		
		21-5M-09	21	1F	33.42	32.28	38.0	24.0	-	14.5	22.5	6.0	9		
		22-5M-09	22	1F	35.01	33.87	39.0	25.5	-	14.5	22.5	6.0	15		
		24-5M-09	24	1F	38.20	37.06	42.0	27.0	-	14.5	22.5	6.0	13		
		26-5M-09	26	1F	41.38	40.24	44.0	30.0	-	14.5	22.5	6.0	12		
		28-5M-09	28	1F	44.56	43.42	48.0	30.5	-	14.5	22.5	6.0	11		
		30-5M-09	30	1F	47.75	46.60	51.0	35.0	-	14.5	22.5	6.0	16		
		32-5M-09	32	1F	50.93	49.79	54.0	38.0	-	14.5	22.5	8.0	18		
		36-5M-09	36	1F	57.30	56.16	60.0	38.0	-	14.5	22.5	8.0	21		
		40-5M-09	40	1F	63.66	62.52	71.0	38.0	-	14.5	22.5	8.0	25		
		ALUMINIUM	WITHOUT FLANGE	44-5M-09	44	3	70.03	68.89	-	38.0	54	14.5	25.5	8.0	-
				48-5M-09	48	3	76.39	75.25	-	45.0	61	14.5	25.5	8.0	-
				60-5M-09	60	3	95.49	94.35	-	45.0	80	14.5	25.5	8.0	-
				72-5M-09	72	3	114.59	113.45	-	45.0	100	14.5	25.5	8.0	-

HTD° 5M 15

CHARACTERISTICS	TYPE	No. of TEETH	EXEC.	Dp PITCH LINE	De EXTERNAL	Df FLANGE	Dm HUB	Di	F	L	d bore Ø	FLANGE No.			
STEEL	WITH FLANGE	12-5M-15	12	1F	19.10	17.96	23.0	13.0	-	20.5	26.0	-	14		
		14-5M-15	14	1F	22.28	21.14	25.0	13.0	-	20.5	26.0	6.0	2		
		15-5M-15	15	1F	23.87	22.73	28.0	16.0	-	20.5	26.0	6.0	4		
		16-5M-15	16	1F	25.46	24.32	28.0	16.5	-	20.5	26.0	6.0	4		
		18-5M-15	18	1F	28.65	27.51	32.0	20.0	-	20.5	26.0	6.0	6		
		20-5M-15	20	1F	31.83	30.69	36.0	23.0	-	20.5	26.0	6.0	8		
		21-5M-15	21	1F	33.42	32.28	38.0	24.0	-	20.5	26.0	6.0	9		
		22-5M-15	22	1F	35.01	33.87	39.0	25.5	-	20.5	26.0	6.0	15		
		24-5M-15	24	1F	38.20	37.06	42.0	27.0	-	20.5	28.0	6.0	13		
		26-5M-15	26	1F	41.38	40.24	44.0	30.0	-	20.5	28.0	6.0	12		
		28-5M-15	28	1F	44.56	43.42	48.0	30.5	-	20.5	28.0	6.0	11		
		30-5M-15	30	1F	47.75	46.60	51.0	35.0	-	20.5	28.0	6.0	16		
		32-5M-15	32	1F	50.93	49.79	54.0	38.0	-	20.5	28.0	8.0	18		
		36-5M-15	36	1F	57.30	56.16	60.0	38.0	-	20.5	28.0	8.0	21		
		40-5M-15	40	1F	63.66	62.52	71.0	38.0	-	20.5	28.0	8.0	25		
		ALUMINIUM	WITHOUT FLANGE	44-5M-15	44	3	70.03	68.89	-	38.0	54	20.5	30.0	8.0	-
				48-5M-15	48	3	76.39	75.25	-	38.0	61	20.5	30.0	8.0	-
				60-5M-15	60	3	95.49	94.35	-	50.0	80	20.5	30.0	8.0	-
				72-5M-15	72	3	114.59	113.45	-	50.0	100	20.5	30.0	8.0	-

N.B. Aluminium pulleys are not phosphated.

PULEGGE CON FORO INIZIALE PER CINGHIE DENTATE POWERGRIP® HTD® "FOSFATATE"

HTD® 5M 25

CHARACTERISTICS		TYPE	No. of TEETH	EXEC.	Dp PITCH LINE	De EXTERNAL	Df FLANGE	Dm HUB	Di	F	L	d bore Ø	FLANGE No.
STEEL	WITH FLANGE	12-5M-25	12	1F	19.10	17.96	23.0	13.0	-	30.5	36	-	14
		14-5M-25	14	1F	22.28	21.14	25.0	13.0	-	30.5	36	6.0	2
		15-5M-25	15	1F	23.87	22.73	28.0	16.0	-	30.5	36	6.0	4
		16-5M-25	16	1F	25.46	24.32	28.0	16.5	-	30.5	36	6.0	4
		18-5M-25	18	1F	28.65	27.51	32.0	20.0	-	30.5	36	6.0	6
		20-5M-25	20	1F	31.83	30.69	36.0	23.0	-	30.5	36	6.0	8
		21-5M-25	21	1F	33.42	32.28	38.0	24.0	-	30.5	38	6.0	9
		22-5M-25	22	1F	35.01	33.87	39.0	25.5	-	30.5	38	6.0	15
		24-5M-25	24	1F	38.20	37.06	42.0	27.0	-	30.5	38	6.0	13
		26-5M-25	26	1F	41.38	40.24	44.0	30.0	-	30.5	38	6.0	12
		28-5M-25	28	1F	44.56	43.42	48.0	30.5	-	30.5	38	6.0	11
		30-5M-25	30	1F	47.75	46.60	51.0	35.0	-	30.5	38	6.0	16
		32-5M-25	32	1F	50.93	49.79	54.0	38.0	-	30.5	38	8.0	18
		36-5M-25	36	1F	57.30	56.16	60.0	38.0	-	30.5	38	8.0	21
		40-5M-25	40	1F	63.66	62.52	71.0	38.0	-	30.5	38	8.0	25
		ALUMINIUM	WITHOUT FLANGE	44-5M-25	44	8	70.03	68.89	-	38.0	-	30.5	40
48-5M-25	48			3	76.39	75.25	-	38.0	61	30.5	40	8.0	-
60-5M-25	60			3	95.49	94.35	-	50.0	80	30.5	40	8.0	-
72-5M-25	72			3	114.59	113.45	-	50.0	100	30.5	40	8.0	-

HTD® 8M 20

CHARACTERISTICS		TYPE	No. of TEETH	EXEC.	Dp PITCH LINE	De EXTERNAL	Df FLANGE	Dm HUB	Di	F	L	d bore Ø	FLANGE No.
STEEL	WITH FLANGE	22-8M-20	22	1F	56.02	54.65	60	43	-	28	38	12	53
		24-8M-20	24	1F	61.12	59.75	66	45	-	28	38	12	69
		26-8M-20	26	1F	66.21	64.85	70	48	-	28	38	12	61
		28-8M-20	28	1F	71.30	70.08	75	50	-	28	38	15	79
		30-8M-20	30	1F	76.39	75.13	83	55	-	28	38	15	73
		32-8M-20	32	1F	81.49	80.16	87	60	-	28	38	15	76
		34-8M-20	34	1F	86.58	85.22	91	66	-	28	38	15	66
		36-8M-20	36	1F	91.67	90.30	97	70	-	28	38	15	68
		38-8M-20	38	1F	96.77	95.39	102	75	-	28	38	15	70
		40-8M-20	40	1F	101.86	100.49	106	75	-	28	38	15	77
		44-8M-20	44	1F	112.05	110.67	120	75	-	28	38	15	75
		48-8M-20	48	1F	122.23	120.86	128	75	-	28	38	15	78
		56-8M-20	56	2F	142.60	141.23	150	80	116	28	38	15	85
		64-8M-20	64	2F	162.97	161.60	168	80	137	28	38	15	90
		72-8M-20	72	2F	183.35	181.97	192	80	158	28	38	15	97
		ALUMINIUM	WITHOUT FLANGE	80-8M-20	80	3	203.72	202.35	-	90	180	28	38
90-8M-20	90			3	229.18	227.81	-	90	204	28	38	15	-
*112-8M-20	112			4	285.21	283.83	-	90	254	28	38	18	-
*144-8M-20	144			4	366.69	365.32	-	90	336	28	38	20	-
*168-8M-20	168			4	427.81	426.44	-	100	400	28	38	20	-
*192-8M-20	192			4	488.92	487.55	-	100	460	28	38	20	-

* Toothings marked with an asterisk are produced on request

HTD[®] PILOT BORE " PHOSPHATED " PULLEYS

HTD[®] 8M 30

CHARACTERISTICS	TYPE	No. of TEETH	EXEC.	Dp PITCH LINE	De EXTERNAL	Df FLANGE	Dm HUB	Di	F	L	d bore Ø	FLANGE No.	
STEEL	WITH FLANGE	22-8M-30	22	1F	56.02	54.65	60	43	-	38	48	12	53
		24-8M-30	24	1F	61.12	59.75	66	45	-	38	48	12	69
		26-8M-30	26	1F	66.21	64.85	70	48	-	38	48	12	61
		28-8M-30	28	1F	71.30	70.08	75	50	-	38	48	15	79
		30-8M-30	30	1F	76.39	75.13	83	55	-	38	48	15	73
		32-8M-30	32	1F	81.49	80.16	87	60	-	38	48	15	76
		34-8M-30	34	1F	86.58	85.22	91	66	-	38	48	15	66
		36-8M-30	36	1F	91.67	90.30	97	70	-	38	48	15	68
		38-8M-30	38	1F	96.77	95.39	102	75	-	38	48	15	70
		40-8M-30	40	1F	101.86	100.49	106	75	-	38	48	15	77
		44-8M-30	44	1F	112.05	110.67	120	75	-	38	48	15	75
		48-8M-30	48	1F	122.23	120.86	128	75	-	38	48	15	78
		56-8M-30	56	2F	142.60	141.23	150	90	116	38	48	15	85
		64-8M-30	64	2F	162.97	161.60	168	90	137	38	48	15	90
		72-8M-30	72	2F	183.35	181.97	192	95	158	38	48	15	97
		CAST IRON	WITHOUT FLANGE	80-8M-30	80	3	203.72	202.35	-	100	180	38	48
90-8M-30	90			3	229.18	227.81	-	100	204	38	48	15	-
112-8M-30	112			4	285.21	283.83	-	100	254	38	48	18	-
144-8M-30	144			4	366.69	365.32	-	100	336	38	48	20	-
168-8M-30	168			4	427.81	426.44	-	100	400	38	48	20	-
192-8M-30	192			4	488.92	487.55	-	100	460	38	48	20	-

HTD[®] 8M 50

CHARACTERISTICS	TYPE	No. of TEETH	EXEC.	Dp PITCH LINE	De EXTERNAL	Df FLANGE	Dm HUB	Di	F	L	d bore Ø	FLANGE No.	
STEEL	WITH FLANGE	22-8M-50	22	1F	56.02	54.65	60	43	-	60	70	-	53
		24-8M-50	24	1F	61.12	59.75	66	45	-	60	70	-	69
		26-8M-50	26	1F	66.21	64.85	70	48	-	60	70	-	61
		28-8M-50	28	1F	71.30	70.08	75	50	-	60	70	-	79
		30-8M-50	30	1F	76.39	75.13	83	55	-	60	70	-	73
		32-8M-50	32	1F	81.49	80.16	87	60	-	60	70	-	76
		34-8M-50	34	1F	86.58	85.22	91	66	-	60	70	-	66
		36-8M-50	36	1F	91.67	90.30	97	70	-	60	70	-	68
		38-8M-50	38	1F	96.77	95.39	102	75	-	60	70	-	70
		40-8M-50	40	1F	101.86	100.49	106	75	-	60	70	-	77
		44-8M-50	44	1F	112.05	110.67	120	75	-	60	70	-	75
		48-8M-50	48	1F	122.23	120.86	128	80	-	60	70	-	78
		56-8M-50	56	6F	142.60	141.23	150	90	116	60	60	18	85
		64-8M-50	64	6F	162.97	161.60	168	100	137	60	60	18	90
		72-8M-50	72	6F	183.35	181.97	192	100	158	60	60	18	97
		CAST IRON	WITHOUT FLANGE	80-8M-50	80	7	203.72	202.35	-	110	180	60	60
90-8M-50	90			7	229.18	227.81	-	110	204	60	60	18	-
112-8M-50	112			5	285.21	283.83	-	110	254	60	60	18	-
144-8M-50	144			5	366.69	365.32	-	110	336	60	60	20	-
168-8M-50	168			5	427.81	426.44	-	120	400	60	60	20	-
192-8M-50	192			5	488.92	487.55	-	130	460	60	60	20	-

HTD[®] PILOT BORE " PHOSPHATED " PULLEYS

HTD[®] 8M 85

CHARACTERISTICS	TYPE	No. of TEETH	EXEC.	Dp PITCH LINE	De EXTERNAL	Df FLANGE	Dm HUB	Di	F	L	d bore Ø	FLANGE No.	
STEEL	WITH FLANGE	22-8M-85	22	1F	56.02	54.65	60	43	-	95	105	-	53
		24-8M-85	24	1F	61.12	59.75	66	45	-	95	105	-	69
		26-8M-85	26	1F	66.21	64.85	70	48	-	95	105	-	61
		28-8M-85	28	1F	71.30	70.08	75	50	-	95	105	-	79
		30-8M-85	30	1F	76.39	75.13	83	55	-	95	105	-	73
		32-8M-85	32	1F	81.49	80.16	87	60	-	95	105	-	76
		34-8M-85	34	1F	86.58	85.22	91	66	-	95	105	-	66
		36-8M-85	36	1F	91.67	90.30	97	70	-	95	105	-	68
		38-8M-85	38	1F	96.77	95.39	102	75	-	95	105	-	70
		40-8M-85	40	1F	101.86	100.49	106	75	-	95	105	-	77
	44-8M-85	44	1F	112.05	110.67	120	75	-	95	105	-	75	
	48-8M-85	48	1F	122.23	120.86	128	80	-	95	105	-	78	
	56-8M-85	56	1F	142.60	141.23	150	90	-	95	105	20	85	
	64-8M-85	64	6F	162.97	161.60	168	100	137	95	95	20	90	
	72-8M-85	72	6F	183.35	181.97	192	100	158	95	95	20	97	
	CAST IRON	WITHOUT FLANGE	80-8M-85	80	5	203.72	202.35	110	180	95	95	20	-
			90-8M-85	90	5	229.18	227.81	110	204	95	95	20	-
			112-8M-85	112	5	285.21	283.83	110	254	95	95	24	-
			144-8M-85	144	5	366.69	365.32	110	336	95	95	24	-
			*168-8M-85	168	5	427.81	426.44	120	400	95	95	24	-
*192-8M-85			192	5	488.92	487.55	130	460	95	95	24	-	

HTD[®] 14M 40

CHARACTERISTICS	TYPE	No. of TEETH	EXEC.	Dp PITCH LINE	De EXTERNAL	Df FLANGE	Dm HUB	Di	F	L	d bore Ø	FLANGE No.			
STEEL	WITH FLANGE	28-14M-40	28	1F	124.78	122.12	128	100	-	54	69	24	153		
		*29-14M-40	29	1F	129.23	126.57	138	100	-	54	69	24	154		
		30-14M-40	30	1F	133.69	130.99	138	100	-	54	69	24	154		
		32-14M-40	32	1F	142.60	139.88	154	100	-	54	69	24	160		
		34-14M-40	34	1F	151.52	148.79	160	100	-	54	69	24	166		
		36-14M-40	36	1F	160.43	157.68	168	100	-	54	69	24	168		
		38-14M-40	38	1F	169.34	166.60	183	120	-	54	69	24	172		
		40-14M-40	40	1F	178.25	175.49	188	120	-	54	69	24	162		
		44-14M-40	44	1F	196.08	193.28	211	120	-	54	69	24	175		
		48-14M-40	48	2F	213.90	211.11	226	135	170	54	69	24	180		
		56-14M-40	56	2F	249.55	246.76	256	135	207	54	69	28	182		
		64-14M-40	64	2F	285.21	282.41	296	135	240	54	69	28	184		
		CAST IRON	WITHOUT FLANGE	72-14M-40	72	4	320.86	318.06	-	135	278	54	69	28	-
				80-14M-40	80	4	356.51	353.71	-	135	314	54	69	28	-
90-14M-40	90			4	401.07	398.28	-	135	358	54	69	28	-		
112-14M-40	112			4	499.11	496.32	-	135	456	54	69	28	-		
*144-14M-40	144			4	641.71	638.92	-	135	600	54	69	28	-		
*168-14M-40	168			4	748.66	745.87	-	135	706	54	69	28	-		
*192-14M-40	192			4	855.62	852.82	-	135	813	54	69	28	-		
*216-14M-40	216			4	962.57	959.76	-	150	920	54	69	28	-		

* Toothings marked with an asterisk are produced on request

HTD® PILOT BORE " PHOSPHATED " PULLEYS

HTD® 14M 55

CHARACTERISTICS	TYPE	No. of TEETH	EXEC.	Dp PITCH LINE	De EXTERNAL	Df FLANGE	Dm HUB	Di	F	L	d bore Ø	FLANGE No.		
STEEL	WITH FLANGE	28-14M-55	28	1F	124.78	122.12	128	100	-	70	85	24	153	
		*29-14M-55	29	1F	129.23	126.57	138	100	-	70	85	24	154	
		30-14M-55	30	1F	133.69	130.99	138	100	-	70	85	24	154	
		32-14M-55	32	1F	142.60	139.88	154	100	-	70	85	24	160	
		34-14M-55	34	1F	151.52	148.79	160	100	-	70	85	24	166	
		36-14M-55	36	1F	160.43	157.68	168	100	-	70	85	24	168	
		38-14M-55	38	1F	169.34	166.6	183	120	-	70	85	24	172	
		40-14M-55	40	1F	178.25	175.49	188	120	-	70	85	24	162	
	44-14M-55	44	1F	196.08	193.28	211	120	-	70	85	24	175		
	48-14M-55	48	6F	213.90	211.11	226	135	170	70	70	24	180		
	56-14M-55	56	6F	249.55	246.76	256	135	207	70	70	28	182		
	64-14M-55	64	6F	285.21	282.41	296	135	240	70	70	28	184		
	CAST IRON	WITHOUT FLANGE	72-14M-55	72	5	320.86	318.06	-	135	278	70	70	28	-
			80-14M-55	80	5	356.51	353.71	-	135	314	70	70	28	-
			90-14M-55	90	5	401.07	398.28	-	135	358	70	70	28	-
			112-14M-55	112	5	499.11	496.32	-	135	456	70	70	28	-
144-14M-55			144	5	641.71	638.92	-	135	600	70	70	28	-	
168-14M-55			168	5	748.66	745.87	-	135	706	70	70	28	-	
192-14M-55			192	5	855.62	852.82	-	135	813	70	70	28	-	
*216-14M-55			216	5	962.57	959.76	-	150	920	70	70	28	-	

HTD® 14M 85

CHARACTERISTICS	TYPE	No. of TEETH	EXEC.	Dp PITCH LINE	De EXTERNAL	Df FLANGE	Dm HUB	Di	F	L	d bore Ø	FLANGE No.		
STEEL	WITH FLANGE	28-14M-85	28	1F	124.78	122.12	128	100	-	102	117	-	153	
		*29-14M-85	29	1F	129.23	126.57	138	100	-	102	117	-	154	
		30-14M-85	30	1F	133.69	130.99	138	100	-	102	117	-	154	
		32-14M-85	32	1F	142.60	139.88	154	100	-	102	117	-	160	
		34-14M-85	34	1F	151.52	148.79	160	100	-	102	117	-	166	
		36-14M-85	36	1F	160.43	157.68	168	100	-	102	117	-	168	
		38-14M-85	38	1F	169.34	166.60	183	120	-	102	117	-	172	
		40-14M-85	40	1F	178.25	175.49	188	135	-	102	117	-	162	
	44-14M-85	44	1F	196.08	193.28	211	135	-	102	117	-	175		
	48-14M-85	48	1F	213.90	211.11	226	150	-	102	117	-	180		
	56-14M-85	56	6F	249.55	246.76	256	150	207	102	102	32	182		
	64-14M-85	64	6F	285.21	282.41	296	150	240	102	102	32	184		
	CAST IRON	WITHOUT FLANGE	72-14M-85	72	5	320.86	318.06	-	150	278	102	102	32	-
			80-14M-85	80	5	356.51	353.71	-	150	314	102	102	32	-
			90-14M-85	90	5	401.07	398.28	-	150	358	102	102	32	-
			112-14M-85	112	5	499.11	496.32	-	150	456	102	102	32	-
144-14M-85			144	5	641.71	638.92	-	150	600	102	102	32	-	
168-14M-85			168	5	748.66	745.87	-	150	706	102	102	32	-	
192-14M-85			192	5	855.62	852.82	-	165	813	102	102	32	-	
*216-14M-85			216	5	962.57	959.76	-	165	920	102	102	32	-	

* Toothings marked with an asterisk are produced on request

HTD[®] PILOT BORE " PHOSPHATED " PULLEYS

HTD[®] 14M 115

CHARACTERISTICS	TYPE	No. of TEETH	EXEC.	Dp PITCH LINE	De EXTERNAL	Df FLANGE	Dm HUB	Di	F	L	d bore Ø	FLANGE No.			
STEEL	WITH FLANGE	28-14M-115	28	1F	124.78	122.12	128	100	-	133	148	-	153		
		*29-14M-115	29	1F	129.23	126.57	138	100	-	133	148	-	154		
		30-14M-115	30	1F	133.69	130.99	138	100	-	133	148	-	154		
		32-14M-115	32	1F	142.60	139.88	154	100	-	133	148	-	160		
		34-14M-115	34	1F	151.52	148.79	160	100	-	133	148	-	166		
		36-14M-115	36	1F	160.43	157.68	168	120	-	133	148	-	168		
		38-14M-115	38	1F	169.34	166.60	183	120	-	133	148	-	172		
		40-14M-115	40	1F	178.25	175.49	188	135	-	133	148	-	162		
		44-14M-115	44	1F	196.08	193.28	211	140	-	133	148	-	175		
		48-14M-115	48	1F	213.90	211.11	226	150	-	133	148	-	180		
		56-14M-115	56	1F	249.55	246.76	256	150	-	133	148	-	182		
		CAST IRON	WITHOUT FLANGE	64-14M-115	64	6F	285.21	282.41	296	150	240	133	133	32	184
				72-14M-115	72	5	320.86	318.06	-	150	278	133	133	32	-
				80-14M-115	80	5	356.51	353.71	-	150	314	133	133	32	-
				90-14M-115	90	5	401.07	398.28	-	150	358	133	133	32	-
112-14M-115	112			5	499.11	496.32	-	150	456	133	133	32	-		
144-14M-115	144			5	641.71	638.92	-	165	600	133	133	32	-		
168-14M-115	168			5	748.66	745.87	-	165	706	133	133	32	-		
192-14M-115	192			5	855.62	852.82	-	165	813	133	133	32	-		
*216-14M-115	216			5	962.57	959.76	-	165	920	133	133	32	-		

HTD[®] 14M 170

CHARACTERISTICS	TYPE	No. of TEETH	EXEC.	Dp PITCH LINE	De EXTERNAL	Df FLANGE	Dm HUB	Di	F	L	d bore Ø	FLANGE No.			
STEEL	WITH FLANGE	28-14M-170	28	1F	124.78	122.12	128	100	-	187	202	-	153		
		*29-14M-170	29	1F	129.23	126.57	138	100	-	187	202	-	154		
		30-14M-170	30	1F	133.69	130.99	138	100	-	187	202	-	154		
		32-14M-170	32	1F	142.60	139.88	154	100	-	187	202	-	160		
		34-14M-170	34	1F	151.52	148.79	160	100	-	187	202	-	166		
		36-14M-170	36	1F	160.43	157.68	168	120	-	187	202	-	168		
		38-14M-170	38	1F	169.34	166.60	183	135	-	187	202	-	172		
		40-14M-170	40	1F	178.25	175.49	188	140	-	187	202	-	162		
		*44-14M-170	44	1F	196.08	193.28	211	160	-	187	202	-	175		
		*48-14M-170	48	1F	213.90	211.11	226	160	-	187	202	-	180		
		*56-14M-170	56	1F	249.55	246.76	256	160	-	187	202	-	182		
		*64-14M-170	64	1F	285.21	282.41	296	180	-	187	202	-	184		
		CAST IRON	WITHOUT FLANGE	*72-14M-170	72	7	320.86	318.06	-	180	278	187	187	32	-
				80-14M-170	80	7	356.51	353.71	-	180	314	187	187	32	-
				90-14M-170	90	5	401.07	398.28	-	180	358	187	187	38	-
112-14M-170	112			5	499.11	496.32	-	200	456	187	187	38	-		
144-14M-170	144			5	641.71	638.92	-	220	600	187	187	38	-		
168-14M-170	168			5	748.66	745.87	-	220	706	187	187	38	-		
*192-14M-170	192			5	855.61	852.82	-	220	813	187	187	38	-		
*216-14M-170	216			5	962.57	959.76	-	220	920	187	187	38	-		

* Toothings marked with an asterisk are produced on request