

Kuličková ložiska pro vysoké teploty

BHTS ZZ GR CG 350°

Kuličková ložiska BHTS ZZ GR CG 350° projektovaná na bázi standardních ložisek, avšak s použitím stabilizačního zpracování; ošetření povrchu, radiální vůle, speciální grafitové poudro se osvědčují při práci v teplotě od -50° do +350°. Doporučený rozsah teplot pro použití je v rozmezí 280° a 350°.

Charakteristickým rysem těchto ložisek je práce bez použití jakéhokoli mazadla, jelikož mazání je zajištěno přímo grafitovou poudrem, což je činí „zeleným“ díky nemožnosti jakkoli poškodit životní prostředí.

Technické parametry:

Materiál ocel AISI 52100 (Chróm) stabilizovaný k užití
Povlak fosfátu manganu na všech ocelových částech
Radiál x4 C5
Vrstvená ocel typu ZZ
Grafitová klec jako celek

Oblasti využití:

Lakovací kabiny
Ocelářský průmysl
Pece pro keramický průmysl
Vozíky pro vypalovací pece na výrobu cihel

Kuličková ložiska pro vysoké teploty

BHTS ZZ GR CG 350° (Seria 6000)

Max. teplota 350° C Celsia

Max. teplota 662° F Fahrenheita

Doporučený rozsah 270°/350° C

Doporučený rozsah 520°/662° F

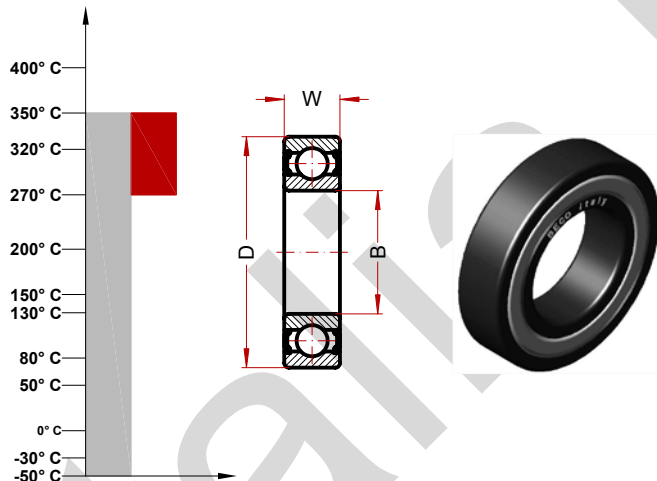

Značení	Vnitřní průměr (B)	Vnější průměr (D)	Šířka (W)	Hmotnost, g	Rychlost ot./min. (*)	Statická zátěž, Kn
6000 BHTS ZZ GR CG 350°	10	26	8	20	90	1.14
6001 BHTS ZZ GR CG 350°	12	28	8	25	85	1.37
6002 BHTS ZZ GR CG 350°	15	32	9	30	80	1.65
6003 BHTS ZZ GR CG 350°	17	35	10	40	75	1.88
6004 BHTS ZZ GR CG 350°	20	42	12	69	70	2.89
6005 BHTS ZZ GR CG 350°	25	47	12	80	65	3.38
6006 BHTS ZZ GR CG 350°	30	55	13	120	60	4.62
6007 BHTS ZZ GR CG 350°	35	62	14	160	55	6.01
6008 BHTS ZZ GR CG 350°	40	68	15	190	50	6.80
6009 BHTS ZZ GR CG 350°	45	75	16	250	45	8.27
6010 BHTS ZZ GR CG 350°	50	80	16	260	40	9.02
6011 BHTS ZZ GR CG 350°	55	90	18	390	40	12.26
6012 BHTS ZZ GR CG 350°	60	95	18	420	40	13.43
6013 BHTS ZZ GR CG 350°	65	100	18	440	40	14.45
6014 BHTS ZZ GR CG 350°	70	110	20	600	40	18.21
6015 BHTS ZZ GR CG 350°	75	115	20	640	40	19.65

Static load and max speed are calculated for the maximum temperature of application we supply this technical information only for help customer in the choice. Due the extremely difference in the condition of application. We suggest to the customer to contact our engineering service and made practical test for check in the real condition the practical working.

Kuličková ložiska pro vysoké teploty

BHTS ZZ GR CG 350° (Seria 6200)

Max. teplota 350° C Celsia

Max. teplota 662° F Fahrenheita

Doporučený rozsah 270°/350° C

Doporučený rozsah 520°/662° F

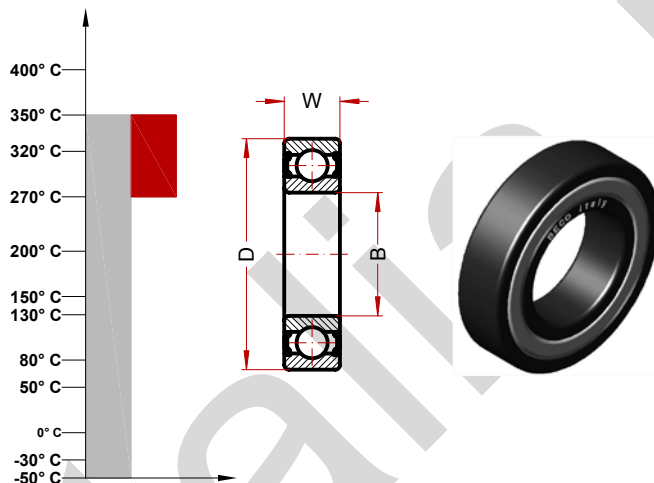

Značení	Vnitřní průměr (B)	Vnější průměr (D)	Šířka (W)	Hmotnost, g	Rychlost ot./min. (*)	Statická zátěž, Kn
6200 BHTS ZZ GR CG 350°	10	30	9	30	90	1.50
6201 BHTS ZZ GR CG 350°	12	32	10	37	85	1.79
6202 BHTS ZZ GR CG 350°	15	35	11	45	80	2.17
6203 BHTS ZZ GR CG 350°	17	40	12	65	75	2.75
6204 BHTS ZZ GR CG 350°	20	47	14	110	70	3.79
6205 BHTS ZZ GR CG 350°	25	52	15	130	65	4.62
6206 BHTS ZZ GR CG 350°	30	62	16	200	60	6.48
6207 BHTS ZZ GR CG 350°	35	72	17	290	55	8.50
6208 BHTS ZZ GR CG 350°	40	80	18	370	50	10.40
6209 BHTS ZZ GR CG 350°	45	85	19	410	45	11.79
6210 BHTS ZZ GR CG 350°	50	90	20	460	40	13.86
6211 BHTS ZZ GR CG 350°	55	100	21	610	40	16.90
6212 BHTS ZZ GR CG 350°	62	110	22	780	40	20.81
6213 BHTS ZZ GR CG 350°	65	120	23	990	40	23.99
6214 BHTS ZZ GR CG 350°	70	125	24	1040	40	25.43
6215 BHTS ZZ GR CG 350°	75	130	25	1210	40	28.32

Static load and max speed are calculated for the maximum temperature of application we supply this technical information only for help customer in the choice. Due the extremely difference in the condition of application. We suggest to the customer to contact our engineering service and made practical test for check in the real condition the practical working.

Kuličková ložiska pro vysoké teploty

BHTS ZZ GR CG 350° (Seria 6300)

Max. teplota 350° C Celsia

Max. teplota 662° F Fahrenheita

Doporučený rozsah 270°/350° C

Doporučený rozsah 520°/662° F

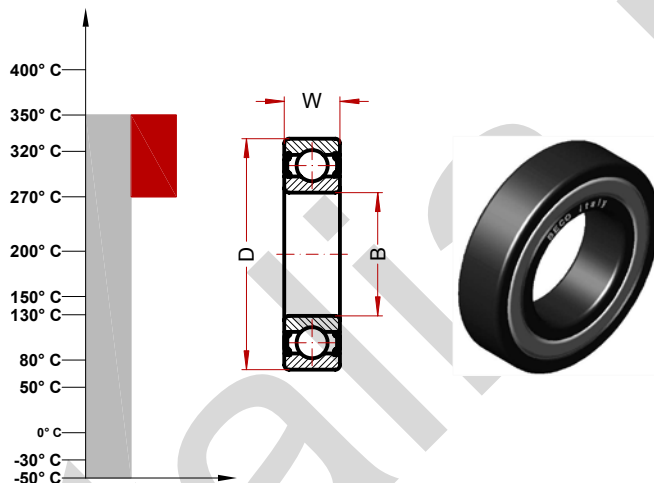

Značení	Vnitřní průměr (B)	Vnější průměr (D)	Šířka (W)	Hmotnost, g	Rychlost ot./min. (*)	Statická zátěž, Kn
6300 BHTS ZZ GR CG 350°	10	35	11	52	90	1.99
6301 BHTS ZZ GR CG 350°	12	37	12	60	85	2.40
6302 BHTS ZZ GR CG 350°	15	42	13	80	80	3.12
6303 BHTS ZZ GR CG 350°	17	47	14	120	75	3.79
6304 BHTS ZZ GR CG 350°	20	52	15	140	70	4.91
6305 BHTS ZZ GR CG 350°	25	62	17	225	65	6.59
6306 BHTS ZZ GR CG 350°	30	72	19	350	60	9.35
6307 BHTS ZZ GR CG 350°	35	80	21	450	55	10.98
6308 BHTS ZZ GR CG 350°	40	90	23	620	50	14.45
6309 BHTS ZZ GR CG 350°	45	100	25	830	45	18.50
6310 BHTS ZZ GR CG 350°	50	110	27	1050	40	21.25
6311 BHTS ZZ GR CG 350°	55	120	29	1350	40	27.46
6312 BHTS ZZ GR CG 350°	60	130	31	1700	40	30.06
6313 BHTS ZZ GR CG 350°	65	140	33	2100	40	34.68
6314 BHTS ZZ GR CG 350°	70	150	35	2500	40	39.10
6315 BHTS ZZ GR CG 350°	75	160	37	3000	40	44.20

Static load and max speed are calculated for the maximum temperature of application we supply this technical information only for help customer in the choice. Due the extremely difference in the condition of application. We suggest to the customer to contact our engineering service and made practical test for check in the real condition the practical working.

Kuličková ložiska pro vysoké teploty

BHTS ZZ GR CG 350° (Seria UC)

Max. teplota 350° C Celsia

Max. teplota 662° F Fahrenheita

Doporučený rozsah 270°/350° C

Doporučený rozsah 520°/662° F

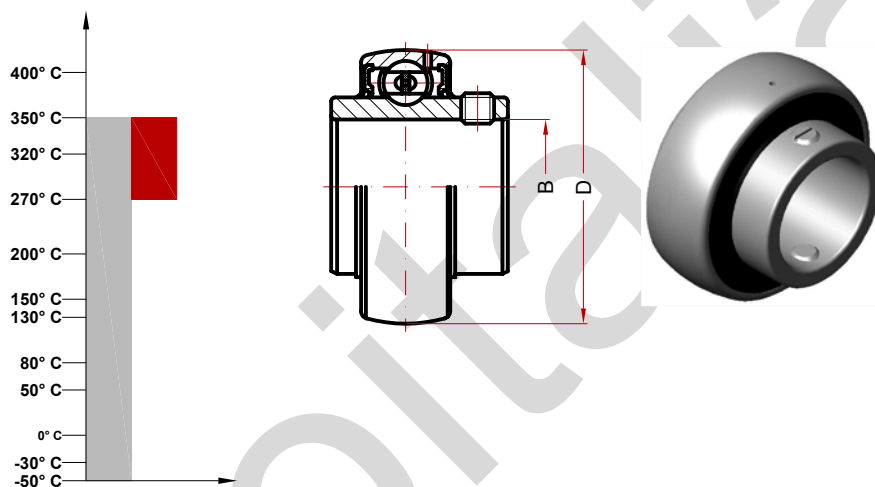

Značení	Vnitřní průměr (B)	Vnější průměr (D)	Rychlost ot./min. (*)
UC 201 BHTS ZZ GR CG 350°	12	40	85
UC 202 BHTS ZZ GR CG 350°	15	40	80
UC 203 BHTS ZZ GR CG 350°	17	40	75
UC 204 BHTS ZZ GR CG 350°	20	47	70
UC 205 BHTS ZZ GR CG 350°	25	52	65
UC 206 BHTS ZZ GR CG 350°	30	62	60
UC 207 BHTS ZZ GR CG 350°	35	72	55
UC 208 BHTS ZZ GR CG 350°	40	80	50
UC 209 BHTS ZZ GR CG 350°	45	85	45
UC 210 BHTS ZZ GR CG 350°	50	90	40
UC 211 BHTS ZZ GR CG 350°	55	100	40
UC 212 BHTS ZZ GR CG 350°	60	110	40
UC 213 BHTS ZZ GR CG 350°	65	120	40
UC 214 BHTS ZZ GR CG 350°	70	125	40
UC 215 BHTS ZZ GR CG 350°	75	130	40

Static load and max speed are calculated for the maximum temperature of application we supply this technical information only for help customer in the choice. Due the extremely difference in the condition of application. We suggest to the customer to contact our engineering service and made practical test for check in the real condition the practical working.

Kuličková ložiska pro vysoké teploty

BHTS ZZ GR CG 350° (Seria UCPA)

Max. teplota 350° C Celsia

Max. teplota 662° F Fahrenheita

Doporučený rozsah 270°/350° C

Doporučený rozsah 520°/662° F

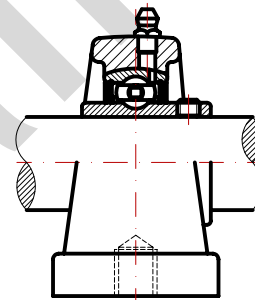
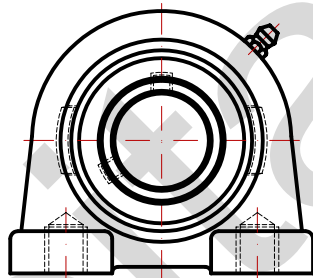
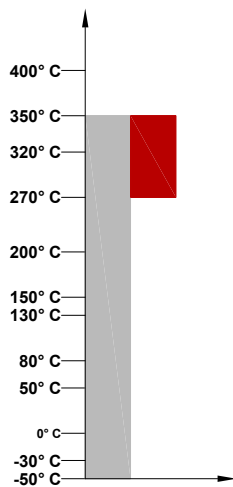
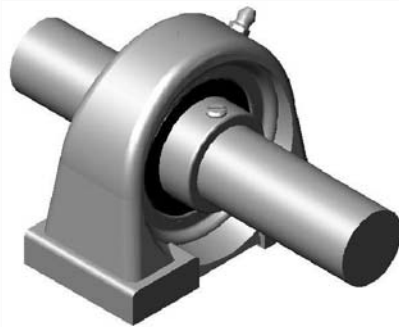

Značení	Ložisko	Těleso
UCPA 201 BHTS ZZ GR CG 350°	UC 201 BHTS ZZ GR CG 350°	SS PA 201
UCPA 202 BHTS ZZ GR CG 350°	UC 202 BHTS ZZ GR CG 350°	SS PA 202
UCPA 203 BHTS ZZ GR CG 350°	UC 203 BHTS ZZ GR CG 350°	SS PA 203
UCPA 204 BHTS ZZ GR CG 350°	UC 204 BHTS ZZ GR CG 350°	SS PA 204
UCPA 205 BHTS ZZ GR CG 350°	UC 205 BHTS ZZ GR CG 350°	SS PA 205
UCPA 206 BHTS ZZ GR CG 350°	UC 206 BHTS ZZ GR CG 350°	SS PA 206
UCPA 207 BHTS ZZ GR CG 350°	UC 207 BHTS ZZ GR CG 350°	SS PA 207
UCPA 208 BHTS ZZ GR CG 350°	UC 208 BHTS ZZ GR CG 350°	SS PA 208
UCPA 209 BHTS ZZ GR CG 350°	UC 209 BHTS ZZ GR CG 350°	SS PA 209
UCPA 210 BHTS ZZ GR CG 350°	UC 210 BHTS ZZ GR CG 350°	SS PA 210
UCPA 211 BHTS ZZ GR CG 350°	UC 211 BHTS ZZ GR CG 350°	SS PA 211
UCPA 212 BHTS ZZ GR CG 350°	UC 212 BHTS ZZ GR CG 350°	SS PA 212
UCPA 213 BHTS ZZ GR CG 350°	UC 213 BHTS ZZ GR CG 350°	SS PA 213
UCPA 214 BHTS ZZ GR CG 350°	UC 214 BHTS ZZ GR CG 350°	SS PA 214
UCPA 215 BHTS ZZ GR CG 350°	UC 215 BHTS ZZ GR CG 350°	SS PA 215

Static load and max speed are calculated for the maximum temperature of application we supply this technical information only for help customer in the choice. Due the extremely difference in the condition of application. We suggest to the customer to contact our engineering service and made pratical test for check in the real condition the pratical working.

Kuličková ložiska pro vysoké teploty

BHTS ZZ GR CG 350° (Seria UCF)

Max. teplota 350° C Celsia

Max. teplota 662° F Fahrenheita

Doporučený rozsah 270°/350° C

Doporučený rozsah 520°/662° F

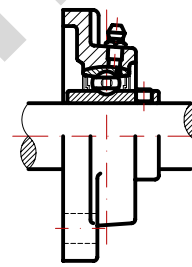
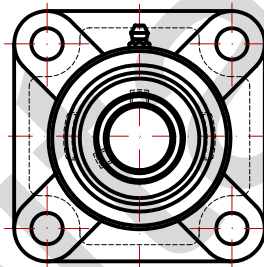
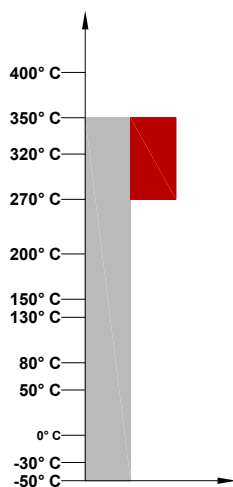
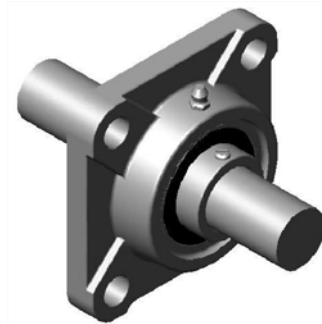

Značení	Ložisko	Těleso
UCF 201 BHTS ZZ GR CG 350°	UC 201 BHTS ZZ GR CG 350°	SS F 201
UCF 202 BHTS ZZ GR CG 350°	UC 202 BHTS ZZ GR CG 350°	SS F 202
UCF 203 BHTS ZZ GR CG 350°	UC 203 BHTS ZZ GR CG 350°	SS F 203
UCF 204 BHTS ZZ GR CG 350°	UC 204 BHTS ZZ GR CG 350°	SS F 204
UCF 205 BHTS ZZ GR CG 350°	UC 205 BHTS ZZ GR CG 350°	SS F 205
UCF 206 BHTS ZZ GR CG 350°	UC 206 BHTS ZZ GR CG 350°	SS F 206
UCF 207 BHTS ZZ GR CG 350°	UC 207 BHTS ZZ GR CG 350°	SS F 207
UCF 208 BHTS ZZ GR CG 350°	UC 208 BHTS ZZ GR CG 350°	SS F 208
UCF 209 BHTS ZZ GR CG 350°	UC 209 BHTS ZZ GR CG 350°	SS F 209
UCF 210 BHTS ZZ GR CG 350°	UC 210 BHTS ZZ GR CG 350°	SS F 210
UCF 211 BHTS ZZ GR CG 350°	UC 211 BHTS ZZ GR CG 350°	SS F 211
UCF 212 BHTS ZZ GR CG 350°	UC 212 BHTS ZZ GR CG 350°	SS F 212
UCF 213 BHTS ZZ GR CG 350°	UC 213 BHTS ZZ GR CG 350°	SS F 213
UCF 214 BHTS ZZ GR CG 350°	UC 214 BHTS ZZ GR CG 350°	SS F 214
UCF 215 BHTS ZZ GR CG 350°	UC 215 BHTS ZZ GR CG 350°	SS F 215

Static load and max speed are calculated for the maximum temperature of application we supply this technical information only for help customer in the choice. Due the extremely difference in the condition of application. We suggest to the customer to contact our engineering service and made pratical test for check in the real condition the pratical working.

Kuličková ložiska pro vysoké teploty

BHTS ZZ CG 350° (Seria UCP)

Max. teplota 350° C Celsia

Max. teplota 662° F Fahrenheita

Doporučený rozsah 270°/350° C

Doporučený rozsah 520°/662° F

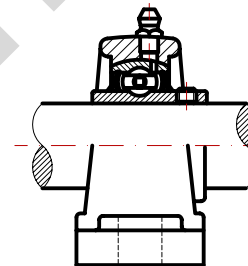
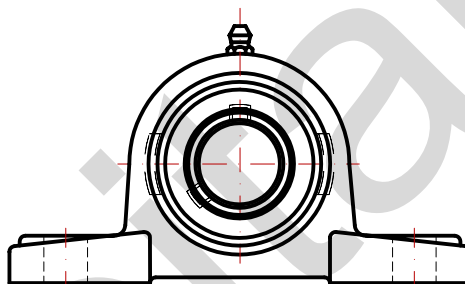
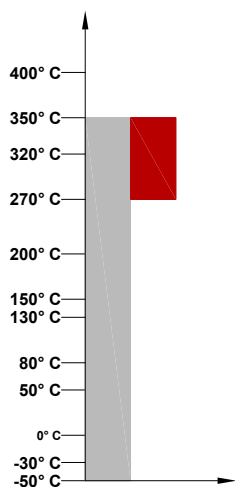
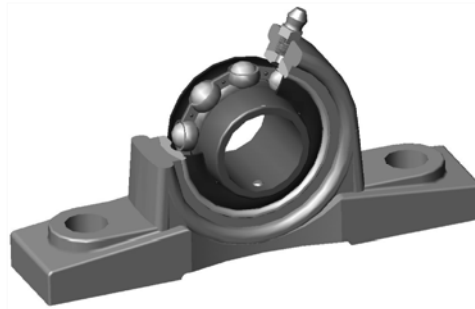

Značení	Ložisko	Těleso
UCP 201 BHTS ZZ GR CG 350°	UC 201 BHTS ZZ GR CG 350°	SS P 201
UCP 202 BHTS ZZ GR CG 350°	UC 202 BHTS ZZ GR CG 350°	SS P 202
UCP 203 BHTS ZZ GR CG 350°	UC 203 BHTS ZZ GR CG 350°	SS P 203
UCP 204 BHTS ZZ GR CG 350°	UC 204 BHTS ZZ GR CG 350°	SS P 204
UCP 205 BHTS ZZ GR CG 350°	UC 205 BHTS ZZ GR CG 350°	SS P 205
UCP 206 BHTS ZZ GR CG 350°	UC 206 BHTS ZZ GR CG 350°	SS P 206
UCP 207 BHTS ZZ GR CG 350°	UC 207 BHTS ZZ GR CG 350°	SS P 207
UCP 208 BHTS ZZ GR CG 350°	UC 208 BHTS ZZ GR CG 350°	SS P 208
UCP 209 BHTS ZZ GR CG 350°	UC 209 BHTS ZZ GR CG 350°	SS P 209
UCP 210 BHTS ZZ GR CG 350°	UC 210 BHTS ZZ GR CG 350°	SS P 210
UCP 211 BHTS ZZ GR CG 350°	UC 211 BHTS ZZ GR CG 350°	SS P 211
UCP 212 BHTS ZZ GR CG 350°	UC 212 BHTS ZZ GR CG 350°	SS P 212
UCP 213 BHTS ZZ GR CG 350°	UC 213 BHTS ZZ GR CG 350°	SS P 213
UCP 214 BHTS ZZ GR CG 350°	UC 214 BHTS ZZ GR CG 350°	SS P 214
UCP 215 BHTS ZZ GR CG 350°	UC 215 BHTS ZZ GR CG 350°	SS P 215

Static load and max speed are calculated for the maximum temperature of application we supply this technical information only for help customer in the choice. Due the extremely difference in the condition of application. We suggest to the customer to contact our engineering service and made pratical test for check in the real condition the pratical working.